

DOUBLE HORIZONTAL

HANDLE LONGER GOODS MORE EFFICIENTLY

TECHNICAL SPECIFICATIONS

NOTE: EVERYTHING CAN BE CUSTOMIZED FOR YOUR NEEDS

- > LIFT CAPACITY: FROM 1000 - 8000 KG
- > TRAVEL: 550 - 1600 MM.
- > CLOSED HEIGHT: 160 - 350 MM.
- > LENGTH: 1800 - 5000 MM.
- > WIDTH: 650 - 2000 MM.
- > POWER SUPPLY: 3x400 V/50 Hz+PE
- > CE MARKED
- > AVAILABLE IN RAL COLOURS, STAINLESS OR GALVANIZED STEEL, HYGIENIC DESIGN AND ATEX
- > RUNS 10 LIFTS PER HOUR 8 HOURS A DAY (FULL TRAVEL)
- PLEASE INQUIRE FOR INTENSIVE USE
- > 4 SAFETY LOCKS FOR MAINTENANCE
- > SAFETY TRIP BAR IN ALUMINIUM
- > 2 COMPONENT POLYURETHANE PAINT (RAL)



The double horizontal lifting table is ideal for lifting long items and heavy duty lifting. The lifting table has a low closed height compared to platform size.

A lifting table improves both efficiency and productivity while relieving your employees from everyday stresses caused by bending and lifting. A lifting table can provide a solution whenever heavy lifting, awkward working positions and height variations is a challenge.

Our standard program has numerous types of lifting tables that each can be adapted to exactly suit your work flow needs. See our standard double horizontal models on the following page or find more information at www.translyft.com/uk/.



The lifting tables can be equipped with many different options such as roller conveyor.



A double horizontal table is also popular to use as a work platform and can e.g. be equipped with rails, stairs and truck sleeve.

Type/Capacity kg	Travel mm	Closed height mm	Total raised height mm	Length mm	Width mm	Lift time sec	Motor kW	Weight kg
TRH 1000	550	160	710	1800	650	15	0,75	180
TLH 2000 A	830	180	1010	2600	650	39	0,75	290
TLH 2000	830	180	1010	2600	800	39	0,75	325
TLH 4000	820	210	1030	2600	800	50	1,1	445
TBH 2000	1000	210	1210	3000	800	39	0,75	460
TBH 2000 F	1000	210	1210	3000	1000	39	0,75	495
TMH 3000	1100	230	1330	3400	900	50	1,1	565
TMH 3000 F	1100	230	1330	3400	1200	50	1,1	660
TMH 6000	1100	250	1350	3400	900	46	3	790
TAH 2000 A	1400	250	1650	4000	900	39	2,2	820
TAH 2000	1400	250	1650	4000	1200	39	2,2	885
TAH 4000 A	1400	250	1650	4000	900	62	3	920
TAH 4000	1400	250	1650	4000	1200	62	3	1010
TAH 8000 B ^	1300	300	1600	4000	1500	108	3	1680
TAH 8000 R ^	1300	300	1600	4000	2000	108	3	1800
TSH 4000	1500	250	1750	4400	1200	62	3	920
TSH 8000 ^	1500	350	1850	4400	1200	108	3	1550
TTH 3000 B	1650	300	1950	5000	1200	39	2,2	1100
TTH 6000	1600	350	1950	5000	1300	62	3	2000

^ separate power unit

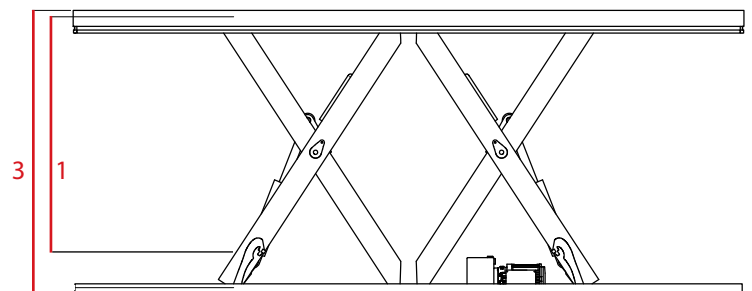
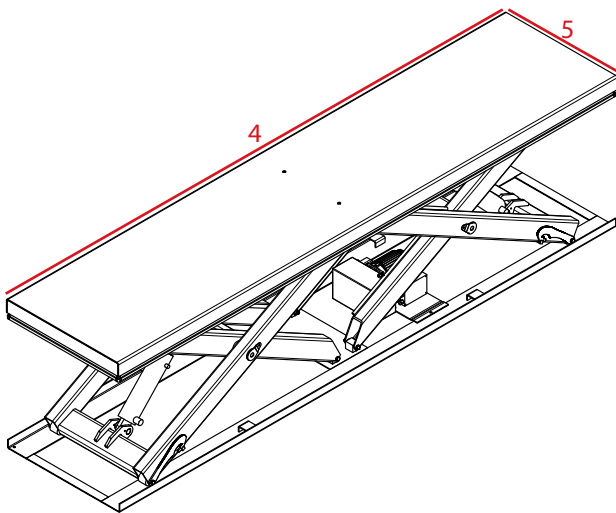

Capacity

Highest load capability (when loaded correctly)

Travel (1)

Travel from closed height to top position

Closed height (2)

Height at lowest position

Total raised height (3)

Height at top position

Length (4)

Platform length

Width (5)

Platform width

Lift time

Time in sec. to top position

Motor

Size of motor

Weight

Weight of table